

COMMUNITY AREA
6399.75 sq.m.

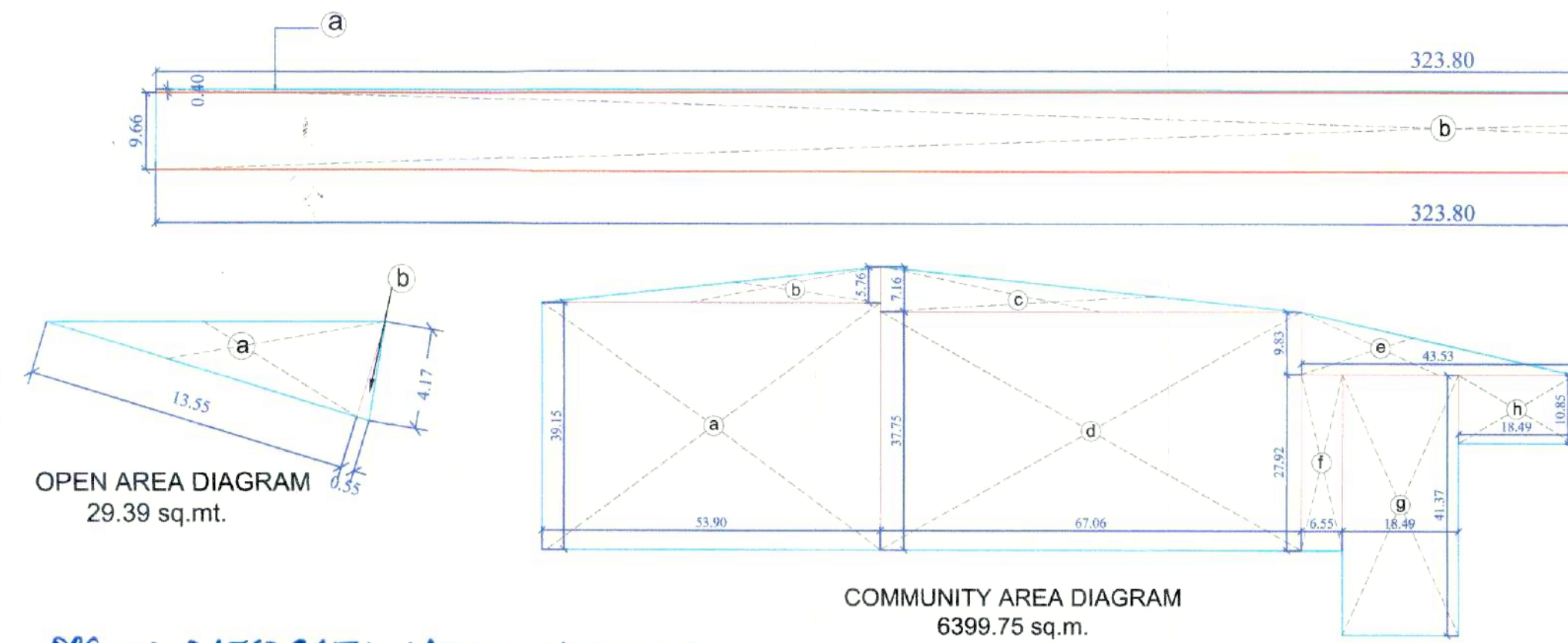

OPEN AREA DIAGRAM
29.39 sq.mt.

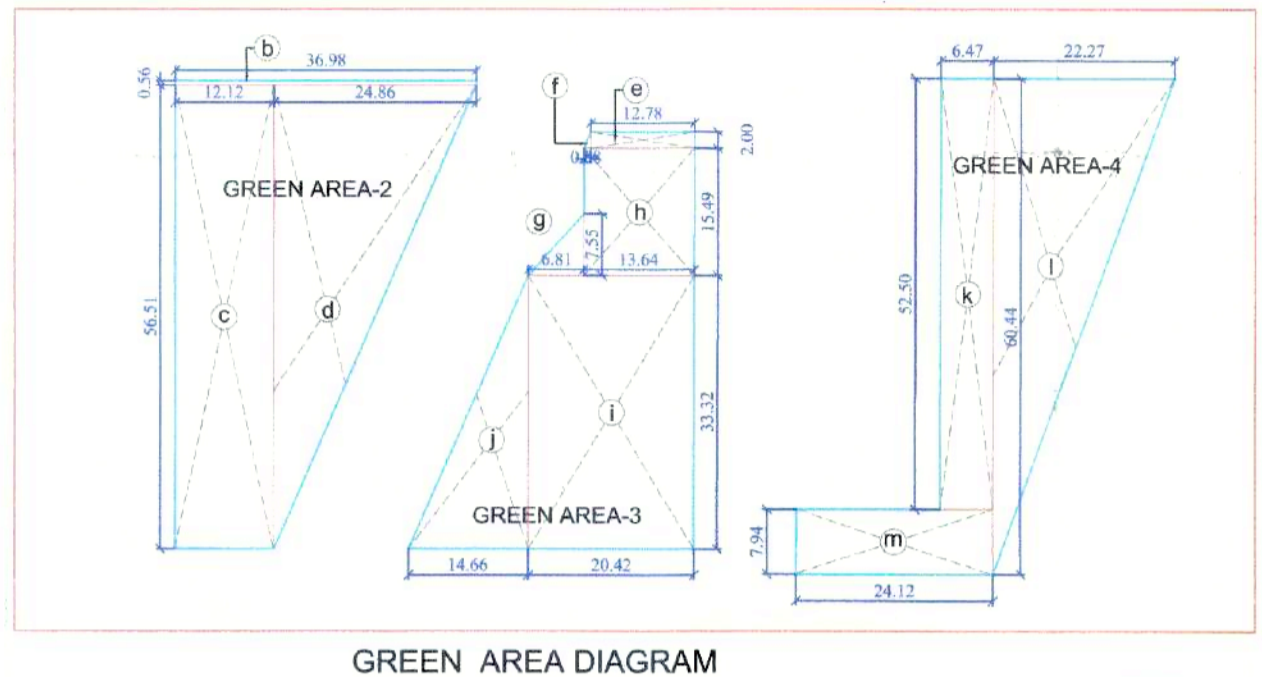

GREEN AREA DIAGRAM
301.48

COMMUNITY AREA DIAGRAM
6399.75 sq.m.

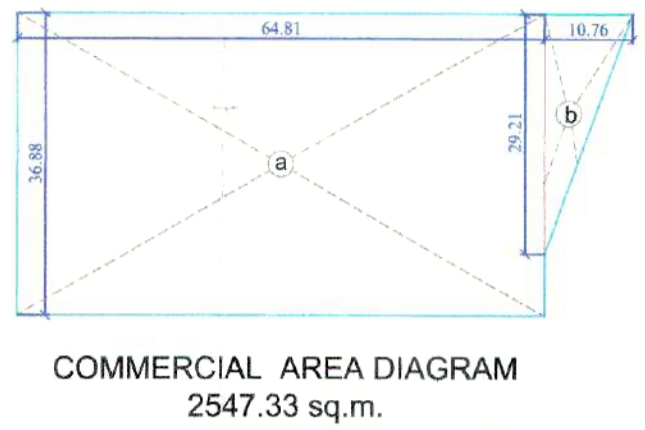

COMMERCIAL AREA DIAGRAM
2547.33 sq.m.

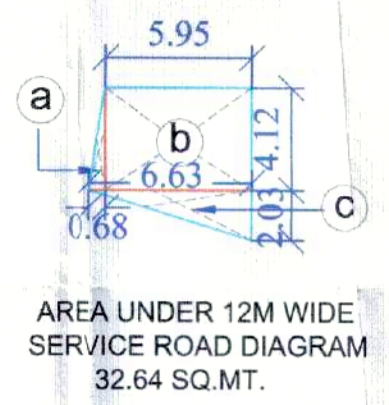

AREA UNDER 12M WIDE SERVICE ROAD DIAGRAM
32.64 SQ.MT.

AREA UNDER 24M WIDE ROAD			
ROAD	S.NO	Dimensions	AREA SQM
1	a	0.5 X 323.80 X 0.40	64.76
	b	9.66 X 323.80	3127.90
	c	0.5X 323.80 X 0.41	66.37
	d	0.5 X 16.74 X 5.11	42.77
	e	20.12 X 17.33	348.67
	f	3.38 x 5.11	17.27
TOTAL AREA			3667.74
2	a	0.5 X 9.08 X 2.05	9.31
	b	9.08 X 132.16	1200.01
	c	0.5X 0.55 X 135.57	37.28
	d	0.5 X 1.50 X 3.41	2.56
	e	0.5 X 4.49 X 10.19	22.87
	f	10.19 X 52.37	533.65
	g	10.19 X 10.99	111.98
	h	0.5 X 10.19 X 4.49	22.87
	i	0.5 X 4.43 X 10.06	22.28
	j	10.61 X 10.06	106.74
	k	0.5 X 4.43 X 10.06	22.28
l	0.5 X 0.88 X 2.01	0.88	
TOTAL AREA			2092.71

AREA UNDER 12M WIDE SERVICE ROAD		
S.NO	SIZE	AREA SQM
a	0.5 X 0.68 X 4.12	1.4
b	5.95 X 4.12	24.51
c	0.5 X 6.63 X 2.03	6.73
TOTAL AREA		32.64

MORTGAGED PLOTS FOR EDC & IDW

PLOT NO.	Dimensions	PLOT AREA	NO.OF PLOT	AREA SQM
A-1 TO A-23	18.44X7.98	147.15	23	3384.45
A-24	7.98x18.44 + (18.44x0.2)/2	147.33	1	147.33
A-25	8 x 18.44 + (18.44 x 0.3)/2	147.80	1	147.80
A-26 TO A-48	18.44X7.98	147.15	23	3384.45
A-49 to A-55	17.65X7.50	132.37	7	926.59
A-56 to A-119	16.94X6.43	108.92	64	6970.88
A-120	16.94X7.34	124.33	1	124.33
A-121 TO A-132	16.94X7.35	124.51	12	1494.12
A-133	16.94X7.34	124.33	1	124.33
A-134	16.94X7.34	124.33	1	124.33
A-135 TO A-140	18.00X7.35	132.30	6	793.80
B-1 TO B-14	18.49X7.63	141.08	14	1975.12
B-15 TO B-18	18.49X7.99	147.74	4	590.96
B-19 TO B-28	18.49X7.63	141.08	10	1410.80
B-29 TO B-42	13.45X5.71	76.80	14	1075.20
B-71 TO B-103	13.00X6.15	79.95	33	2638.35
B-110 to B-139	15.00X6.52	97.80	30	2934.00
B-146 TO B-175	19.90X7.53	149.85	30	4495.50
B-176 to B-184	15.00X6.66	99.90	9	899.10
TOTAL AREA			284	33641.44

OPEN AREA		
S.NO	SIZE	AREA SQM
a	0.5 X 4.17 X 13.55	28.25
b	0.5 X 0.55 X 4.17	1.14
TOTAL AREA		29.39

OTHER'S LAND

AREA STATEMENT				
Total area of scheme	Area in acres	Area in Sq.Mt.	Required %age	Proposed area SQM
	15.8125	63990.91		
Required green area		4799.32	7.5	4817.23
Community site		6399.09	10	6399.75
Commercial area		2559.64	4	2547.33
Area under Plots		39034.59	61	33641.44
Total Saleable area		41594.23	65	36188.77

Population @ 13.5 PERSONS /PLOT =284X13.5=3834
ACHIEVED DENSITY PLOTTED AREA (3834/15.8125) 242.46 P.P.A

COMMUNITY AREA		
S.NO	SIZE	AREA SQM
a	53.90x39.15	2110.18
b	(53.90x5.76)/2	155.23
c	(67.06x7.16)/2	240.07
d	67.06x37.75	2531.89
e	(43.53x9.83)/2	213.95
f	27.92x6.55	182.88
g	41.37x18.49	764.93
h	18.49x10.85	200.62
TOTAL AREA		6399.75

COMMERCIAL AREA		
S.NO	SIZE	AREA SQM
a	64.81 X 36.88	2390.19
b	29.21 X 10.76/2	157.14
TOTAL AREA		2547.33

GREEN AREA CALCULATION			
GREEN AREA	S.NO	SIZE	AREA SQM
1	a	33.87 x 30.00	1016.10
	TOTAL AREA		1016.10
2	b	36.98X 56	20.70
	c	56.51X12.12	684.90
	d	(56.51X24.86)/2	702.41
	TOTAL AREA		1408.01
3	e	12.78x2.00	25.56
	f	2.00x0.88	1.76
	g	(6.81X7.55)/2	25.71
	h	13.64X15.49	211.28
	i	20.42X33.32	680.39
	j	(33.32X14.66)/2	244.24
	TOTAL AREA		1188.94
	4	k	52.50x6.47
l		(60.44x22.27)/2	673.00
m		24.12x7.94	191.51
TOTAL AREA		1204.18	
TOTAL AREA 1+2+3+4		4817.23	

AREA UNDER 24M WIDE ROAD DIAGRAM
3667.74SQ.MT.

12 M WIDE SERVICE ROAD
18 M WIDE GREEN BELT
60 M WIDE SECTOR ROAD

AREA UNDER 24M WIDE ROAD DIAGRAM
2092.71 SQ.MT.

PROJECT TITLE

Layout cum Demarcation PLAN OF AFFORDABLE RESIDENTIAL PLOTTED COLONY UNDER DDJAY 2016 for an Area Measuring 15.8125 ACRES FALLING IN REVENUE ESTATE OF VILLAGE KHERI SADH, SEC-27A, TEHSIL SAMPLA, DISTRICT ROHTAK Being Developed by M/S SPICE ONE BUILDERS PVT LTD (License No 157 of 2023 dated 09.08.2023)



OWNER'S SIGNATURE
For SPICE ONE BUILDERS PVT.LTD.
Chaman Lal
Director/Authorise Signatory

